

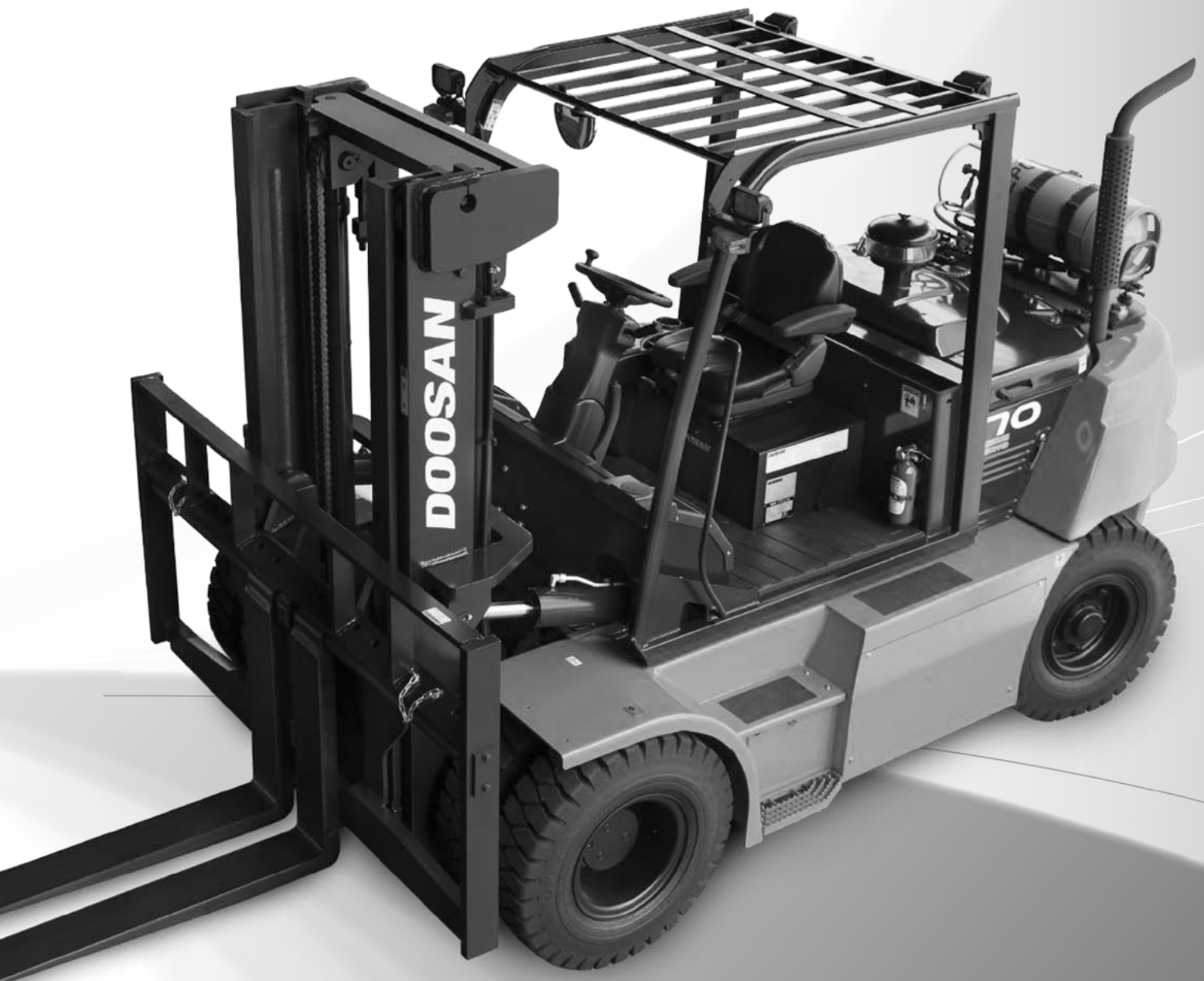

[www.doosan-iv.com](http://www.doosan-iv.com)

## 7 Series Forklifts

Pneumatic LP 13,500 to 15,500 lb Series



*Lifting Your Dreams*

# GENERAL SPECIFICATION

CHARACTERISTICS								
1	Model			G60S-7	G70S-7	G60S-7	G70S-7	
2	Capacity	at rated load center	lb	13,500	15,500	13,500	15,500	
3	Load center	Distance	in	24	24	24	24	
4	Power type	Electric, Diesel, Gasoline, LP-Gas		LPG	LPG	LPG	LPG	
5	Operator type	Stand-on, Rider-seated		Rider-seated	Rider-seated	Rider-seated	Rider-seated	
6	Tire type	C=cushion, P=pneumatic, E=Solid		P/E	P/E	P/E	P/E	
7	Wheels (x=driven)	Number, front/rear		x 4/2	x 4/2	x 4/2	x 4/2	
DIMENSIONS								
8	Maximum fork height	with STD 2-stage mast	in	118	118	118	118	
9	Free lift	with STD 2-stage mast	in	8.1	8.1	8.1	8.1	
10	Fork carriage	ISO class		IV	IV	IV	IV	
11	Forks	Thickness x Width x Length	in	2.4x7.1x47.2	2.4x7.1x47.2	2.4x7.1x47.2	2.4x7.1x47.2	
12		Fork spacing (min X Max)	in	16.1x80.0	16.1x80.0	16.1x80.0	16.1x80.0	
13	Tilt of mast	Forward / Backward	deg	15/10	15/10	15/10	15/10	
14	Overall dimensions	Length to forkface	in	142.4	145.6	142.4	145.6	
15		Width	in	84.9	84.9	84.9	84.9	
16		Mast lowered height	in	98.4	98.4	98.4	98.4	
17		Mast extended height	in	170.1	170.1	170.1	170.1	
18		Overhead guard height (Cabin)	in	97.2	97.2	97.2	97.2	
19		Seat height	in	57.3	57.3	57.3	57.3	
20	Minimum outside turning radius		in	133.1	135.0	133.1	135.0	
21	Load moment constant		in	24.9	24.9	24.9	24.9	
PERFORMANCE								
22	Speed	Ttravel, load/unload	mhp	14.0/14.7	14.0/14.5	14.0/14.7	14.0/14.5	
23		Lift, load/unload	fpm	74.8/80.7	74.8/80.7	74.8/80.7	74.8/80.7	
24		Lowering, load/unload	fpm	96.5/90.6	96.5/90.6	96.5/90.6	96.5/90.6	
25	Drawbar pull	at 1.6 km/h, load	lb	9,396	9,396	9,396	9,396	
26	Gradeability	at 1.6 km/h, load	%	30	26.5	30	26.5	
WEIGHT								
27	Total weight	Unloaded	lb	19,279	20,779	19,279	20,779	
28	Axle load	with load, front/rear	lb	29,640/3,139	32,262/4,017	29,640/3,139	32,262/4,017	
29		without load, front/rear	lb	8,907/10,373	8,455/12,324	8,907/10,373	8,455/12,324	
CHASSIS								
30	Tires	Number of front/rear		4/2	4/2	4/2	4/2	
31		Size, front		8.25x15-14PR	8.25x15-14PR	8.25x15-14PR	8.25x15-14PR	
32		Size, rear		8.25x15-14PR	8.25x15-14PR	8.25x15-14PR	8.25x15-14PR	
33	Wheel base		in	90.6	90.6	90.6	90.6	
34	Tread	Front/Rear	in	62.4/61.0	62.4/61.0	62.4/61.0	62.4/61.0	
35	Ground clearance	load, at the lowest point	in	6.9	6.9	6.9	6.9	
36		load, at center of wheelbase	in	8.1	8.1	8.1	8.1	
37	Brakes	Service brake		Foot / Hyd	Foot / Hyd	Foot / Hyd	Foot / Hyd	
38		Parking brake		Hand / Mechanical	Hand / Mechanical	Hand / Mechanical	Hand / Mechanical	
DRIVE								
39	Battery	Voltage/Capacity	V/AH	12/75	12/75	12/75	12/75	
40	Engine	Manufacturer/Model		PSI 4.3L (TIER III)	PSI 4.3L (TIER III)	PSI 4.3L (NON CERTI)	PSI 4.3L (NON CERTI)	
41		Rated output (at rpm)	kW/rpm		70/2,500	70/2,500	70/2,500	70/2,500
42			HP/rpm		93.8/2,500	93.8/2,500	93.8/2,500	93.8/2,500
43		Max. Torque	N-m/rpm		283.9/1,800	283.9/1,800	283.9/1,800	283.9/1,800
44			lb-ft/rpm		209.4/1,800	209.4/1,800	209.4/1,800	209.4/1,800
45	Cycle/Cylinders/Displacement	cc		4/6/4,294	4/6/4,294	4/6/4,294	4/6/4,294	
46	Transmission	Type		Power Shift	Power Shift	Power Shift	Power Shift	
47		Number of speeds forward/reverse		2/2	2/2	2/2	2/2	
48	Operating pressure	System/Attachment	bar	190/140	215/140	190/140	215/140	

Note : Specification values quoted in this specification sheet has been rounded. Performance may vary due to operation conditions. Products and specifications are subject to improvement and change without prior notices.

# DIMENSIONAL DRAWING

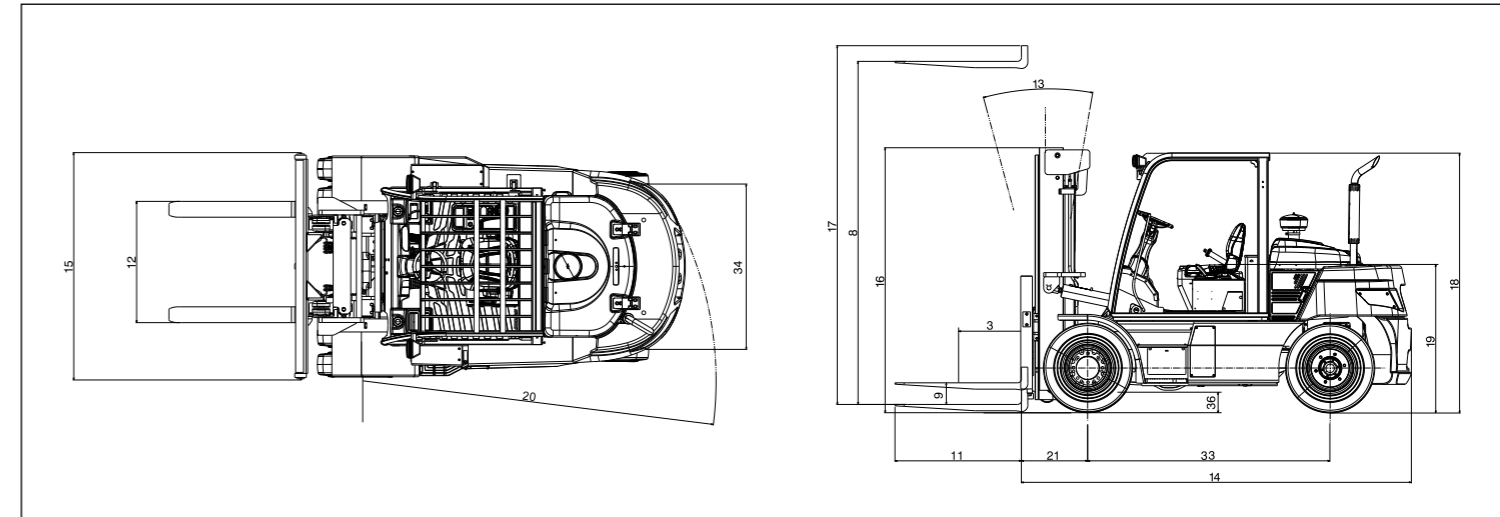

# MAST SPECIFICATIONS and RATED CAPACITIES

## G60S-7

Mast type	Maximum Fork Height	Maximum Lowered Height	Fully Extended Height	Free Lift	Rated Load Capacities		
					G60S-7		
					Tilt Angle		Load Capacities
					Double Pneumatic		Double Pneumatic
					FWD	BWD	LC24in
	in	in	in	in	deg	deg	lb
STD	122	98	168	8	15	10	13200
	130	108	188	8	15	10	13200
	142	112	196	8	15	10	13200
	161	118	208	8	15	10	13200
	181	132	227	8	15	10	13200
	201	142	247	8	15	10	13200
	220	151	267	8	15	10	12900
FFT	171	161	286	8	15	10	12450
	179	100	219	62	15	10	12950
	197	106	237	68	15	10	12550
	220	114	261	76	15	10	12100
	238	120	278	82	15	10	11650

## G70S-7

Mast type	Maximum Fork Height	Maximum Lowered Height	Fully Extended Height	Free Lift	Rated Load Capacities		
					G70S-7		
					Tilt Angle		Load Capacities
					Double Pneumatic		Double Pneumatic
					FWD	BWD	LC24in
	in	in	in	in	deg	deg	lb
STD	118	98	168	8	15	10	15400
	138	108	188	8	15	10	15400
	146	112	196	8	15	10	15400
	157	118	208	8	15	10	15400
	177	132	227	8	15	10	15400
	197	142	247	8	15	10	15400
	217	151	267	8	15	10	15400
	236	161	286	8	15	10	15100
	118	98	168	8	15	10	15400
	138	108	188	8	15	10	15400
	146	112	196	8	15	10	15400
	157	118	208	8	15	10	15400
	177	132	227	8	15	10	15400
	197	142	247	8	15	10	15400
217	151	267	8	15	10	15400	
236	161	286	8	15	10	15150	
FFT	179	100	219	62	15	10	15400
	197	106	237	68	15	10	15400
	220	114	261	76	15	10	14750
	238	120	278	82	15	10	14300

Note : Mast Specifications & Rated Capacities are based on standard chassis with dual pneumatic tire and without side shifter.



*[www.doosan-iv.com](http://www.doosan-iv.com)*

**AUTHORIZED DEALER**